

# HAND DRYERS SENSOR OPERATED SPEEDFLOW



14  
15



## STEEL WHITE FINISH

### M06A

Units per box: 1  
Units per pallet: 36 (E)



LOW CONSUMP.

#### COMPONENTS & MATERIALS

- ▶ Steel one-piece cover white epoxy, 1.5 mm thick.
- ▶ Dimensions: 266,8 x 289 x 100 mm

## STAINLESS STEEL AISI 304 BRIGHT FINISH

### M06AC

Units per box: 1  
Units per pallet: 36 (E)



LOW CONSUMP.

#### COMPONENTS & MATERIALS

- ▶ Stainless steel one-piece cover bright finish, 1.5 mm thick.
- ▶ Dimensions: 266,8 x 289 x 100 mm

## STAINLESS STEEL AISI 304 SATIN FINISH

### M06ACS

Units per box: 1  
Units per pallet: 36 (E)



LOW CONSUMP.

#### COMPONENTS & MATERIALS

- ▶ Stainless steel one-piece cover satin finish, 1.5 mm thick.
- ▶ Dimensions: 266,8 x 289 x 100 mm

- ▶ Cover fixed to the base by means of 2 vandal-proof lock screws and lock with special Speedflow® wrench.
- ▶ Aluminium base, with 4 Ø 8 mm holes for wall mounting. It includes 4 silent-blocks to damp mechanical vibrations.
- ▶ Fire resistant plastic UL 94-V0 fan scroll.
- ▶ High speed motor. Universal brush motor, 3800 - 8200 rpm, A class. RPM may be adjusted manually by means of a potentiometer. The motor includes a self-resetable safety thermal cut-off.
- ▶ Aluminium centrifugal double asymmetrical inlet fan wheel.

- ▶ Waved wire NiCr heating element mounted on a mica frame. It incorporates a self-resetable safety thermal cut-off which disconnects the whole appliance.
- ▶ Automatic disconnection system after 60 seconds of continuous use.
- ▶ Fully adjustable (5 - 25 cm) IR electronic detection sensor by means of a potentiometer.
- ▶ Sensors come with a polycarbonate viewing window.

#### Speedflow: M06A M06AC M06ACS

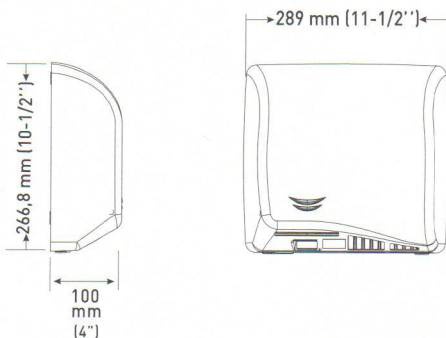

Voltage	100-120 V, 208 V, 220-240 V	Total power	1150 W
Frequency	50/60 Hz	Motor power	250 W
Electrical isolation	Class I	Heating element power	900 W (450 + 450W)
Weight	3,6 Kg	Protection level	IP23
Effective airflow	61-98 m³/h/1017-1634 l/min	Nominal airflow	73-118 m³/h/1217-1967 l/min
Consumption	4,8 A (240 V) 9,5 A (120 V)	Air temperature (at 10 cm distance at 21°C)	41-44 °C
r.p.m.	3800-8200	Drying time	10-12 sec
Air velocity	90-180 Km/h	Noise level (at 2 m)	64-74 dB

NOTE: Drying time may vary depending on conditions

HAND DRYERS SENSOR OPERATED - SPEEDFLOW

# TECHNICAL SPECIFICATIONS