

# HAND DRYERS SENSOR OPERATED SMARTFLOW

**ABS  
WHITE FINISH**

**M04A**

Units per box: 12  
Units per pallet: 96 (L)



**LOW CONSUMP.**

### COMPONENTS & MATERIALS

- ▶ White ABS thermoplastic one-piece cover, 3 mm thick.
- ▶ Dimensions: 258 x 145 x 138 mm.

**ABS  
BRIGHT CHROMED FINISH**

**M04AC**

Units per box: 12  
Units per pallet: 96 (L)



**LOW CONSUMP.**

### COMPONENTS & MATERIALS

- ▶ Bright chromed finish ABS thermoplastic one-piece cover, 3 mm thick.
- ▶ Dimensions: 258 x 145 x 138 mm.

**ABS  
SATIN FINISH**

**M04ACS**

Units per box: 12  
Units per pallet: 96 (L)

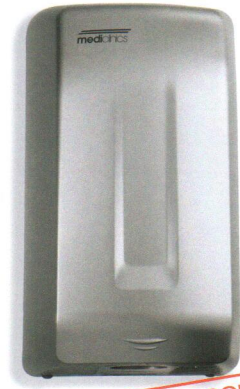

**LOW CONSUMP.**

### COMPONENTS & MATERIALS

- ▶ Satin finish ABS thermoplastic one-piece cover, 3 mm thick.
- ▶ Dimensions: 258 x 145 x 138 mm.

- ▶ Cover fixed to the base by means of 2 vandal-proof lock screws.
- ▶ Thermoplastic PP + talcum base, with 4 Ø 6 mm holes for wall mounting.
- ▶ Universal brush motor, 15000 rpm, B class, includes a self-resetable safety thermal cut-off at 100 °C.

- ▶ PP UL94-V0 helicoidal fan wheel.
- ▶ Waved wire NiCr heating element that incorporates a self-resetable safety thermal cut-off at 95 °C.
- ▶ Adjustable IR electronic detection sensor.
- ▶ Sensors come with a polycarbonate viewing window.

### Smartflow: M04A M04AC M04ACS

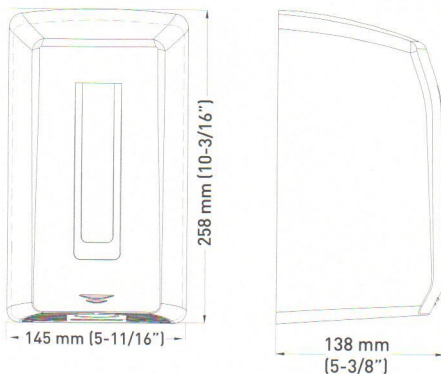

Voltage	220-240 V	Total power	1100 W
Frequency	50/60 Hz	Motor power	150 W
Electrical isolation	Class II	Heating element power	950 W
Consumption	4,8 A	Protection level	IP23
Weight	1,2 Kg	r.p.m.	15000
Effective airflow	96 m <sup>3</sup> /h 1600 l/min	Air temperature (at 10 cm distance at 21°C)	47° C
Nominal airflow	110 m <sup>3</sup> /h/1833 l/min	Drying time	39 sec
Air velocity	85 Km/h	Noise level (at 2 m)	60 dB

NOTE: Drying time may vary depending on conditions

HAND DRYERS - SMARTFLOW

# TECHNICAL SPECIFICATIONS